



Series
NSX

SIZE 5 COAXIAL SOCKET CONTACT
FOR RG58, KX15 AND RG141 CABLES

Issue:
15 NOV 96

Page
1 / 1

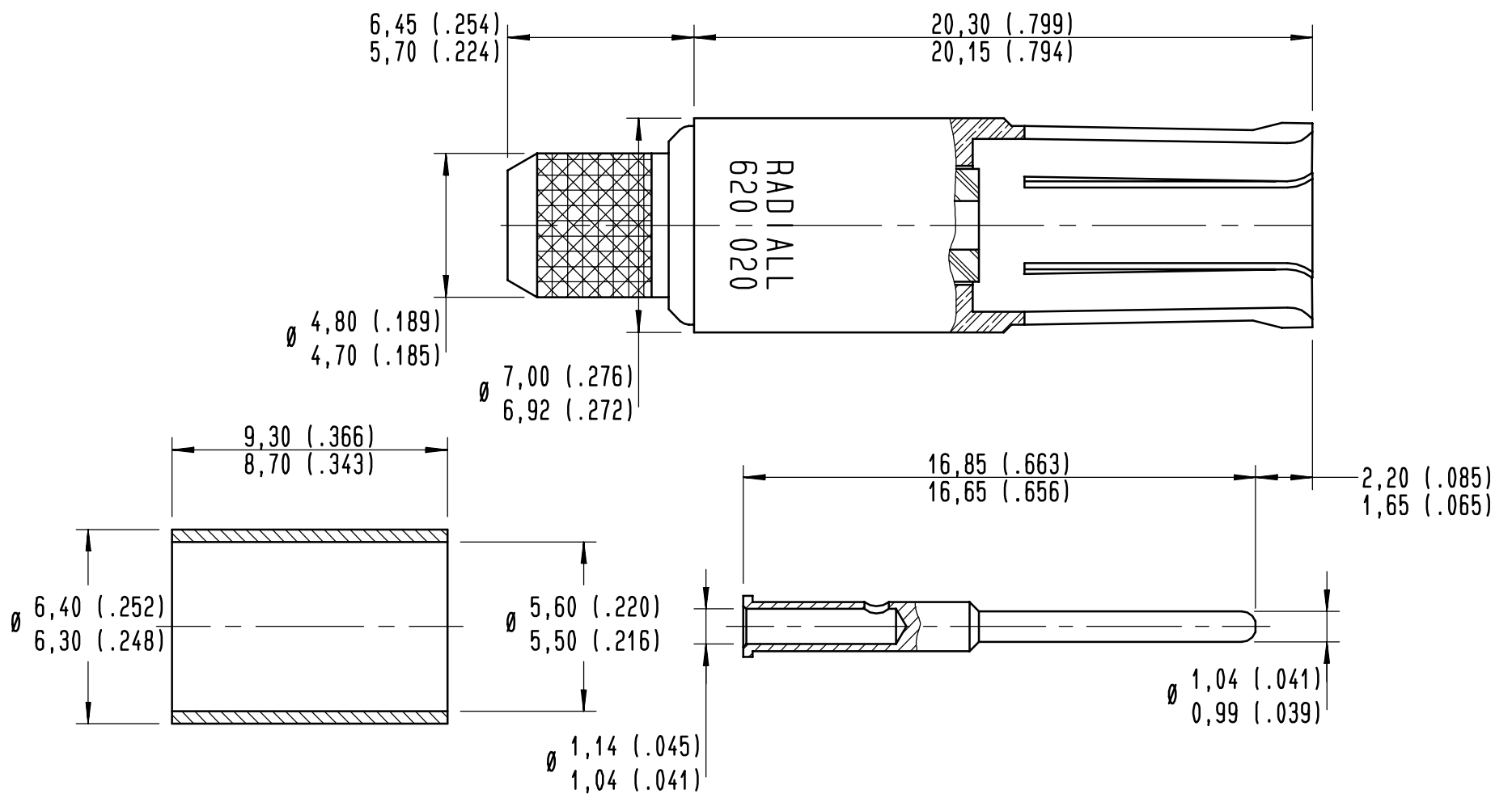

MATERIAL:
 OUTER CONTACT: BERYLLIUM COPPER
 INSULATOR: PTFE
 CENTER CONTACT: BRASS
 FERRULE: BRASS
FINISH (ALL METAL PARTS)
 GOLD PLATE PER MIL-G-45204: 50 MICROINCHES OVER NICKEL

DESIGN REQUIREMENTS
 TEMPERATURE RANGE: -65°C TO +165°C
 IMPEDANCE: 50 OHMS NOMINAL
 RATED VOLTAGE: 325 V RMS AT SEA LEVEL
 VSWR: 1.10:1 FREQUENCY RANGE : 0 - 300 MHZ
 VSWR: 1.30:1 FREQUENCY RANGE : 300 - 500 MHZ
 FREQUENCY RANGE: 0 - 500 MHZ
 DIELECTRIC WITHSTANDING VOLTAGE: 750 VRMS AT SEA LEVEL

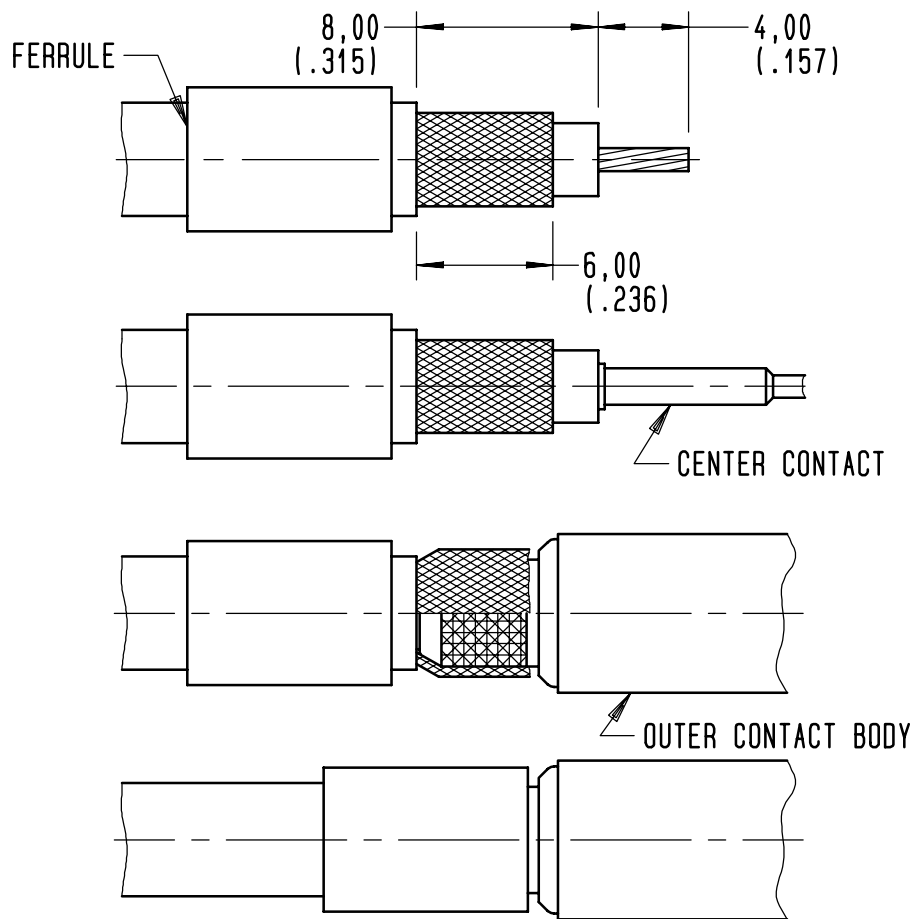

STRIP CABLE TO DIMENSIONS SHOWN ABOVE
 SLIDE FERRULE OVER THE CABLE

SLIDE CENTER CONTACT BARREL OVER CABLE CONDUCTOR
 CONTACT SHOULDER BUTTING AGAINST CABLE DIELECTRIC
 CRIMP CENTER CONTACT
 CRIMPING TOOL M22520/2-01 RADIAL 282281
 SELECTOR ON: 8 FOR RG141
 6 FOR RG58 AND KX15
 POSITIONER: K345 RADIAL 282550

FLARE BRAID, INSERT CENTER CONTACT INTO THE OUTER
 CONTACT BODY
 PLACE BRAID OVER KNURLED PART OF OUTER CONTACT BODY

SLIDE FERRULE OVER BRAID UNTIL IT BUTTS AGAINST SHOULDER
 OF OUTER CONTACT BODY
 CRIMP FERRULE
 CRIMPING TOOL: M22520/5-01 RADIAL 282293
 DIE: M22520/5-05 RADIAL 282246 HEX.A 5,4 (.212) /FLATS
 OR: M22520/5-45 RADIAL 282236 HEX.A 5,54 (.218) /FLATS

CREATION				
PEN: .				
NOM: JP MACARI				
DATE: 17 JUN 82				
APPR.: CARTESSE	15 NOV 96	REDRAWN	VALGRESY	.
	Issue	Revisions	Name	Approved

4112-9610

A620020